



## Submittal Data Sheet VSRI16 ROUND INLINE FAN

Job Name: \_\_\_\_\_

Equipment Rep: \_\_\_\_\_

Contractor: \_\_\_\_\_

Prepared By: \_\_\_\_\_

Arch./Engr.: \_\_\_\_\_

Date: \_\_\_\_\_

**Description:**

VSRI-Series Variable Speed Round Inline Fans are suitable for providing combustion air or ventilation.

Use with the CPC-3 Constant Pressure Controller, closed-loop VFD, and TD-Series Pressure Transducer for an automatic-variable speed system which will modulate to always deliver the perfect amount of combustion air or ventilation. For an adjustable-fixed speed system, use an open-loop VFD to manually adjust the speed of the VSRI.

**Housing Construction:**

Continuously welded, heavy-gauge, corrosion resistant, enamel coated steel housing.

**Impeller Construction:**

Non-overloading, aluminum impeller that is statically and dynamically balanced.

**Motor:**

Three phase, ¾ HP, 208-230/460 VAC, TEFC, E-PLUS 3, Inverter Duty Rated.

**Standard Equipment:**

- 4" x 4" weatherproof junction box
- PSA-1 Fan Proving Switch
- FFP-1 Fire and Freeze Protection Limit

**Optional Equipment:**

- CPC-3 Constant Pressure Controller
- IPS-1 Indoor Pressure Sensor Decorative Cover Fitting
- TD-Series Pressure Transducer
- VFD-Series Variable Frequency Drive

**Listings:**

UL 705 - Power Venters

**Temperature Rating:**

120° F / 49° C

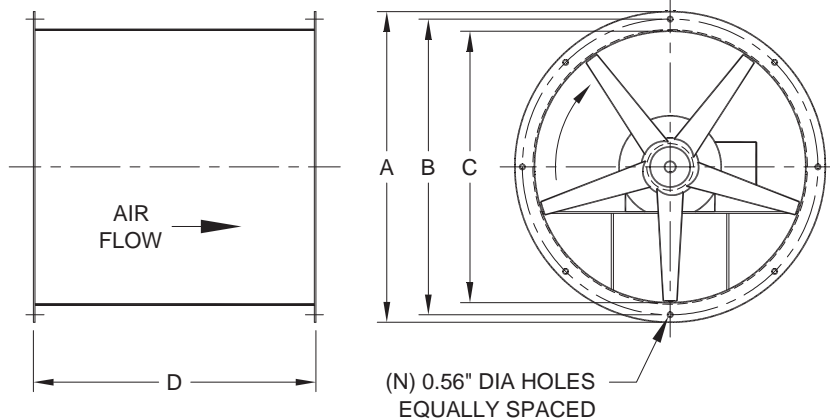

<b>VSRI16</b>	
Fan Type	Tubeaxial
Voltage	3x230 / 3x460
Amps	3.21 / 1.45
RPM	1750
Power Rating	3/4 HP
Weight	53 Lbs
Dimension A	19.63"
Dimension B	17.88"
Dimension C	16.13"
Dimension D	19"
Mounting Holes (N)	(8) 0.56"