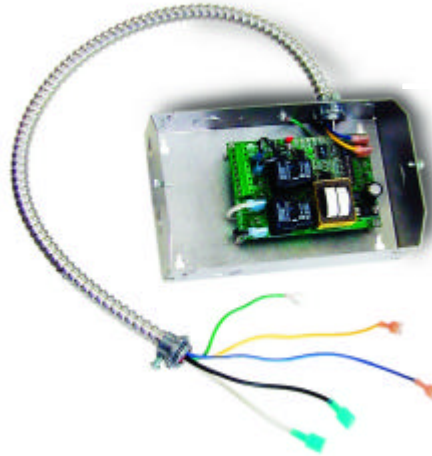

**TJERNLUND PRODUCTS, INC.**

1601 Ninth Street • White Bear Lake, MN 55110-6794
PHONE (800) 255-4208 • (651) 426-2993 • FAX (651) 426-9547
Visit our web site • www.tjernlund.com

**VERSION
X.02 OR
EARLIER**

MODEL UC1 INSTALLATION INSTRUCTIONS

 Recognize this symbol as an indication of important Safety Information!

OWNER INSTRUCTIONS, DO NOT DESTROY

 WARNING

THESE INSTRUCTIONS ARE INTENDED AS AN AID TO QUALIFIED, LICENSED SERVICE PERSONNEL FOR PROPER INSTALLATION, ADJUSTMENT AND OPERATION OF THIS PRODUCT. READ THESE INSTRUCTIONS THOROUGHLY BEFORE ATTEMPTING INSTALLATION OR OPERATION. FAILURE TO FOLLOW THESE INSTRUCTIONS MAY RESULT IN IMPROPER INSTALLATION, ADJUSTMENT, SERVICE OR MAINTENANCE POSSIBLY RESULTING IN FIRE, ELECTRICAL SHOCK, CARBON MONOXIDE POISONING, EXPLOSION, OR PERSONAL INJURY OR PROPERTY DAMAGE.

**DO NOT DESTROY. PLEASE READ CAREFULLY AND
KEEP IN A SAFE PLACE FOR FUTURE REFERENCE.**

TABLE OF CONTENTS

	Page (s)
Description and Specifications	1
Installation Restrictions	1
Cautions	1, 2
UC1 Universal Control Board Features	2
LED Status & Fault Indicators	2
Pre / Post-Purge & Prover Status Check Settings.....	3
Electrical Wiring	
Warnings, Sequence of Operation & Internal Schematic	4
Wiring to Gas Fired Appliance	5, 6, 7
Wiring to Oil Fired Equipment	8, 9
UC1 Operation and Draft Check	10, 11
Troubleshooting Electrical Problems	10, 11
Warranty & Replacement Parts	11, 12

DESCRIPTION

The UC1 is the new standard interlock control for Tjernlund's full line of Power Venters, Draft Inducers and Combustion Air In-Forcers. It can be interlocked with virtually any burner control circuit. Features include: adjustable pre & post purge, LED status / diagnostic indicators, 10 second prover switch delay to avoid burner start up and wind induced short cycling. Interlocks with any 24-120 VAC burner control circuit and also includes "dry" contact actuation option. After each burner cycle the UC1 will continue to operate in post-purge mode to allow the venter to purge the heater and vent of residual flue gases. A factory post-purge time is set at 2 minutes and is adjustable up 16 minutes, see "Pre / Post-purge Settings" on page 3.

GENERAL INFORMATION

Each UC1 is electrically factory line tested before shipment.

After opening carton, inspect thoroughly for hidden damage. If any damage is found notify freight carrier and your distributor immediately and file a concealed damage claim.

Throughout the rest of this installation manual Venter will be synonymous with Power Venter, Draft Inducer or In-Forcer.

INSTALLATION RESTRICTIONS

1. The UC1 Prover Status Check is activated from the factory. When activated the UC1 Universal Control checks across the P1 & P2 safety circuit Fan Prover to verify that the Fan Prover switch is "Open" upon a call for heat and not stuck "Closed". See "Prover Status Check Settings", page 3 for details.
2. A Venter post-purge on the UC1 has been factory set at 2 minutes. Confirm that dip switch #5 is in the up or "on" position. Oil fired equipment requires that the post-purge be long enough to eliminate post cycle nozzle drip odor. A longer post-purge may be necessary for longer vent runs or high heat retention, refractory lined combustion chambers. A shorter post-purge may be desired for gas installations. If using the UC1 to control our combustion air In-Forcers a post-purge may not be desired. See "Pre / Post-Purge Settings", page 3 for details.
3. The UC1 is intended for indoor installation only. Do not mount the UC1 on a heat source that exceeds 140°F (60°C). Examples of improper mounting surfaces include vent pipe, top of heater casing or any place where radiant or convective heat would cause the junction box temperature to exceed 140°F (60°C).

CAUTIONS

WARNING

The UC1 must be installed by a qualified installer (an individual properly licensed and/or trained) in accordance with all local codes or, in their absence, in accordance with the appropriate National Fire Protection Association #31, #54, #211 and the National Electrical Code.

Failure to install, maintain and/or operate the UC1 in accordance with manufacturer's instructions may result in conditions which can produce bodily injury and property damage.

1. The installer must verify that the BTU/hr. input of the appliance does not exceed the recommended input of the any Venter being controlled by the UC1. Refer to the Venter, Inducer or In-Forcer installation instructions for capacities.
2. Disconnect power supply from the UC1 and heating equipment when making wiring connections and servicing the UC1. Failure to do so may result in personal injury and/or equipment damage. LED #5 (RED) should be off with power removed.

- All installation restrictions and instructions in the Venter, Inducer or In-Forcer installation instructions must be adhered to when using the UC1.
- Make certain power source is adequate for the UC1 and Venter requirements. Do not add equipment to a circuit when the total electrical load is unknown.

UC1 UNIVERSAL CONTROL BOARD FEATURES

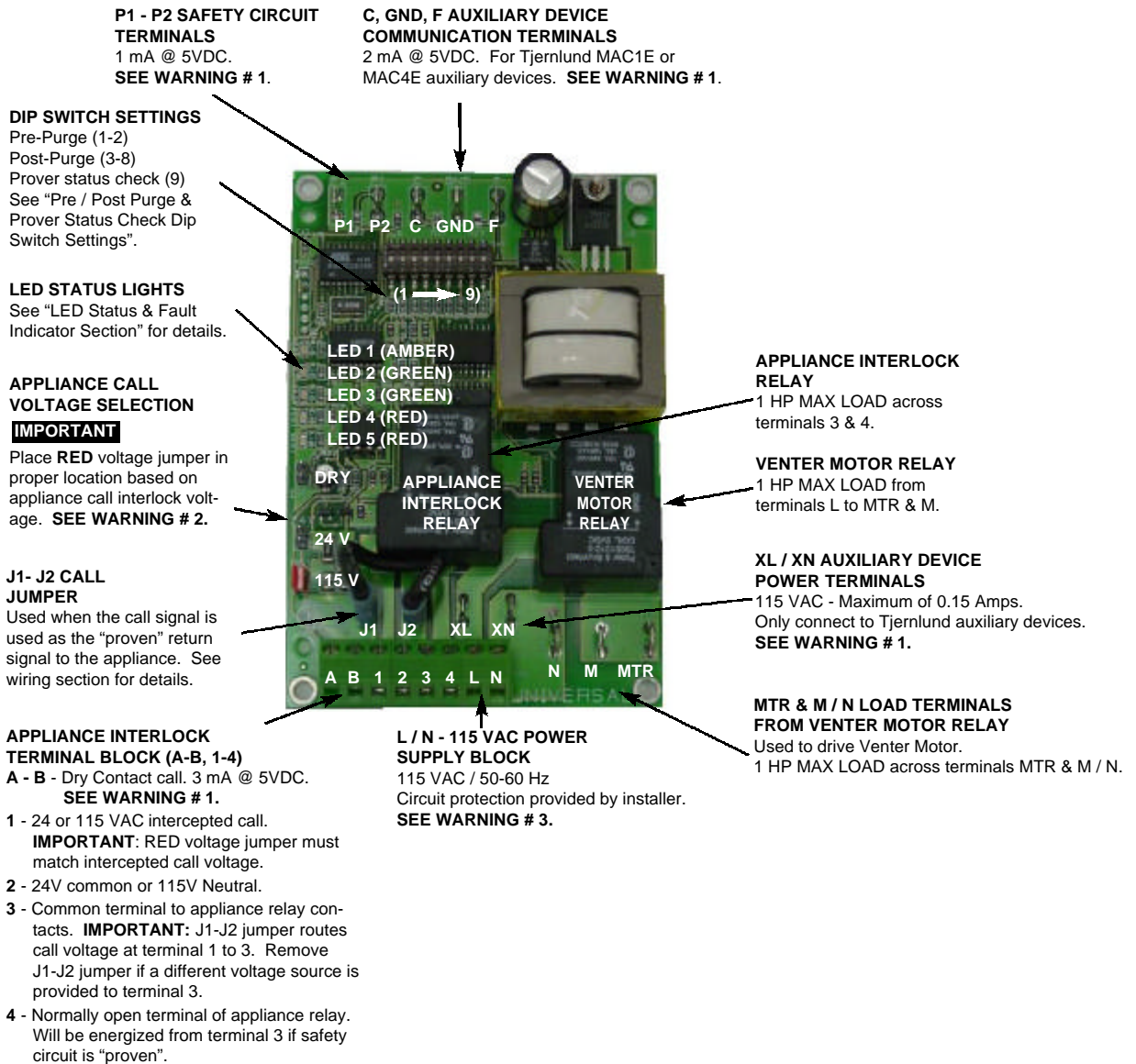

WARNING

- Power supplied by board. Do not supply power to this area or control damage may result.
- Do not supply power to the appliance interlock block with the call selector in the "DRY" position. Control damage may result if power is supplied.
- Circuit protection must be provided by the installer. 16 Amps is the maximum current allowed for this device at terminal L. A 15 Amp circuit breaker is recommended.

LED STATUS & FAULT INDICATORS

LED INDICATOR LIGHTS

- LED #1 (Amber) Appliance call for heat.
- LED #2 (Green) Safety circuit through P1 & P2 (Venter Fan Prover) is verified "Open" upon start-up. Burner circuit is energized with contact closure from terminal 3 to 4. Also verifies Venter prover is closed during run cycle.
- LED #3 (Green) Power switched to Venter motor from L to MTR & M.
- LED #4 (Red) Status indicator.
- LED #5 (Red) 115 VAC power supplied to board. Also used as status indicator.

LED INDICATOR LIGHT STATUS & FAULTS

LED #4 & #5 Flashing Alternately = Prover start up fault. Venter Prover contacts “Closed” across P1 & P2 upon appliance call before Venter is turned on. Prover status check **must** be activated, see page 3.

LED #4 & #5 Flashing in Unison = Fan Prover circuit is “Open” longer than 60 seconds on start-up or 10 seconds during run cycle. Venter Prover contacts are not staying “Closed” across P1 & P2 safety circuit.

LED #4 Flashing & #5 on Continuous = System in Pre-Purge. (Pre-Purge options 0, 15, 30, 60 seconds)

LED #5 Flashing & #4 on Continuous = System in Post-Purge. (Post-Purge options 0, 30 seconds or 1, 2, 4, 8, 16 minutes)

IMPORTANT: To reset faults, verify fault by checking the LEDs and then remove call for heat.

PRE / POST PURGE AND PROVER STATUS CHECK DIP SWITCH SETTINGS

WARNING

Remove power to Venter and heating equipment when installing, servicing or changing dip switch settings. Failure to do so may result in personal injury and/or equipment damage. LED #5 (RED) should not be on if 115 VAC supply power is removed from the control.

Pre-purge

Used for a Venter with longer vent runs to get draft fully established throughout the vent system prior to burner ignition. Also beneficial for negative pressure prone environments. **IMPORTANT:** Pre-purge settings must be shorter than primary control lockout time unless wired prior to primary control (i.e. aquastat / thermostat).

Post-purge

A Venter post-purge has been factory set at 2 minutes. Confirm that dip switch #5 is in the up or “on” position. Oil fired equipment requires that the post-purge be long enough to eliminate post cycle nozzle drip odor. A longer post-purge may be necessary for longer vent runs or high heat retention, refractory lined combustion chambers. A shorter post-purge may be desired for gas installations or when using the UC1 to control a combustion air In-Forcer.

DIP SWITCH NUMBERING

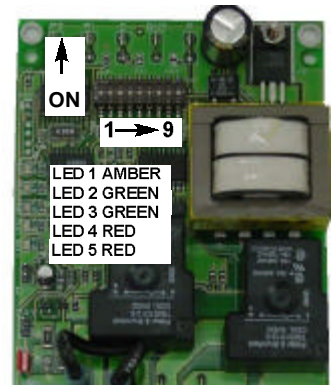
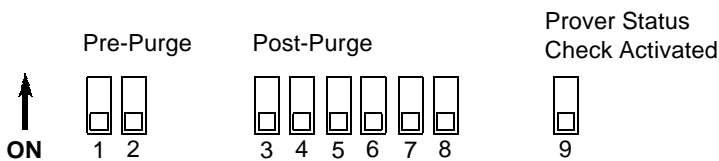

PRE-PURGE SETTINGS

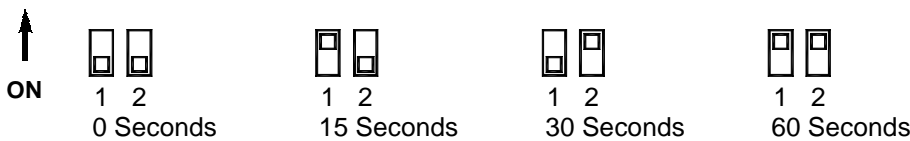

POST-PURGE SETTINGS

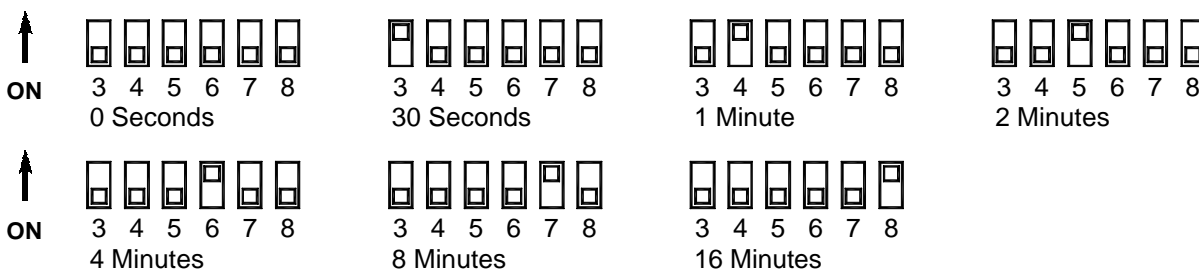

P1 & P2 FAN PROVER SAFETY CIRCUIT “OPEN” UPON APPLIANCE CALL

Prover Status Check Activated The Prover Status Check is activated from the factory. When activated the UC1 Universal Control checks across P1 & P2 safety circuit (Fan Prover) to verify that the Fan Prover switch is “Open” upon a call for heat and not stuck “Closed”. **IMPORTANT: This must always be in the down “Activated” position when side wall venting.** When using the PS1505 Fan Prover in conjunction with a draft inducer on a vertical termination stack, “natural draft” may be sufficient to keep Prover contacts closed prior to a call for heat by an interlocked appliance. This is the only condition where this safety feature should be deactivated. Push up or “ON” to deactivate.

UC1 INSTALLATION

Do not mount the UC1 junction box on a heat source that exceeds 140°F (60°C). Examples of improper mounting surfaces include vent pipe, top of heater casing or any place where radiant or convective heat would cause the junction box temperature to exceed 140°F.

The UC1 is intended for indoor installation only.

Using the key hole slots on the back of the UC1 junction box as a template, mark 4 holes on the mounting surface, drill pilot holes if necessary, and secure junction box using provided screws.

The UC1 has a 2 foot whip that contains a ground lead and the leads to power the Venter motor and connect to the Fan Prover. If it is desirable to mount the UC1 more than 2 feet from the Fan Proving Switch an additional electrical junction box and appropriate length of conduit will be necessary. Any added wire should be 14 gage and a pig tail should be added to each ground wire connection so that each electrical junction box is grounded. See diagram below for a typical UC1, Fan Prover and Venter installation.

TYPICAL UC1, FAN PROVER AND VENTER INSTALLATION

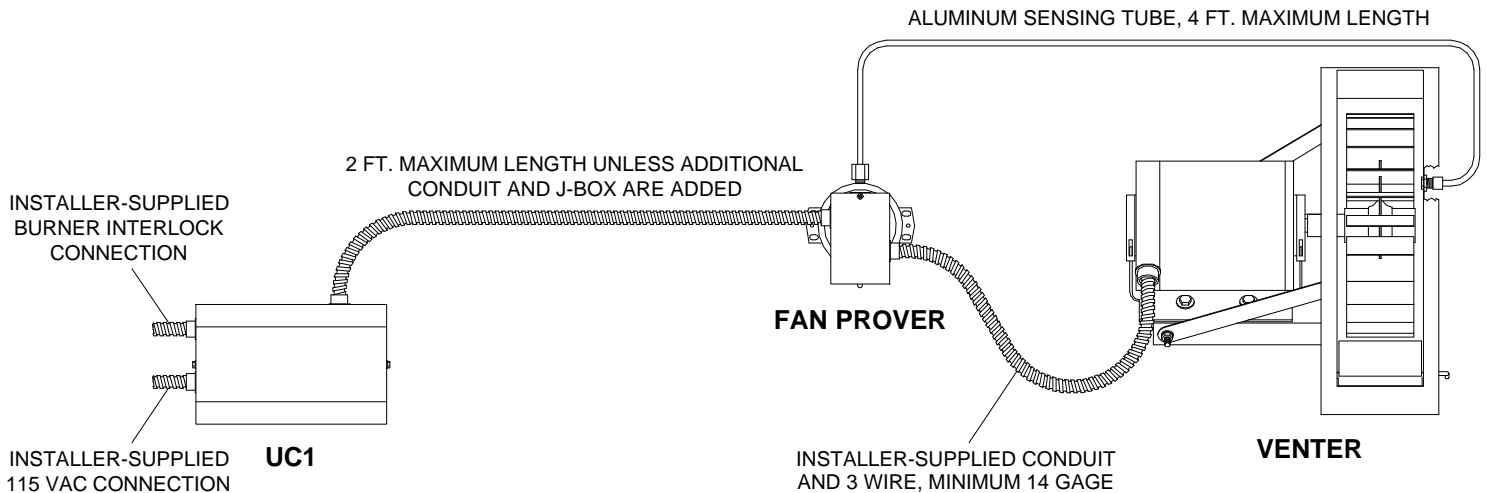

ELECTRICAL WIRING

ELECTRICAL SPECIFICATIONS

POWER REQUIREMENTS	T-BLOCK L / N	120 VAC ±10 %, 50/60 Hz CIRCUIT PROTECTION PROVIDED BY INSTALLER
ADD VENTER MOTOR LOAD PLUS 1/2 AMP FOR UC1 LOAD	XL / XN	150 mA MAX @ 120 VAC, 50/60 Hz CAN ONLY BE CONNECTED TO TJERNLUND-SPECIFIED AUXILIARY DEVICE
	UC1 CONTROL	DURING OPERATION THE CONTROL USES 50 mA MAX @ 120 VAC
	M & MTR (RELAY K2)	MOTOR - 1 H.P. MAX. @ 120 VAC, 50/60 Hz GENERAL PURPOSE - 15A @ 120 VAC, 50/60 Hz
EXTERNAL POWER SWITCHING CAPACITY	T-BLOCK 3 TO 4 (RELAY K1)	MOTOR - 1 H.P. MAX. @ 120 VAC, 50/60 Hz GENERAL PURPOSE - 15A @ 120 VAC, 50/60 Hz RESISTIVE - 10A @ 28 VDC PILOT DUTY - 470 VA
EXTERNAL CALL TRIGGER METHODS	T-BLOCK A / B	USER-PROVIDED CONTACT CLOSURE FROM A TO B. SIZE CONTACT CLOSURE TO HANDLE 3 mA @ 5 VDC. MOVE RED VOLTAGE JUMPER TO "DRY" LOCATION. DO NOT SUPPLY POWER.
	OR 24V 1 / 2	USER-PROVIDED 24 VAC AT TERMINALS 1 & 2. 1 = CALL HOT, 2 = COMMON. CONTROL REQUIRES 5 mA @ 24 VAC TO TRIGGER. MOVE RED VOLTAGE JUMPER TO "24V" LOCATION.
	OR 115V 1 / 2	USER-PROVIDED 115 VAC AT TERMINALS 1 & 2. 1 = CALL LINE, 2 = NEUTRAL. CONTROL REQUIRES 1 mA @ 115 VAC TO TRIGGER. MOVE RED VOLTAGE JUMPER TO "115V" LOCATION.
J1 / J2 JUMPER	J1 / J2	USED TO JUMP CALL HOT (24 VAC) OR CALL LINE (115 VAC) FROM TERMINAL 1 TO TERMINAL 3. REMOVE J1-J2 JUMPER IF A DIFFERENT VOLTAGE SOURCE IS PROVIDED TO TERMINAL 3.
SAFETY CIRCUIT	P1 / P2	CONNECTED TO FAN PROVER. 1 mA @ 5 VDC. DO NOT SUPPLY POWER HERE.

D/N 9183006H

WARNING

All wiring from the UC1 to the appliance must be appropriate Class 1 wiring as follows: installed in rigid metal conduit, intermediate metal conduit, rigid non-metallic conduit, electrical metallic tubing, Type MI Cable, Type MC Cable, or be otherwise suitably protected from physical damage.

SEQUENCE OF OPERATION WITH UC1 UNIVERSAL CONTROL:

Control signal from thermostat, aquastat, primary control or gas valve is intercepted and routed to terminal "1" on UC1 terminal strip. When terminal "1" is energized with either 24 VAC or 120 VAC, the Venter motor is energized. After draft is established, the Fan Proving Switch closes within 5 to 10 seconds energizing terminal "4", which completes the circuit allowing burner to fire.

NOTE: If a Venter pre-purge is selected, the burner will not fire until the pre-purge time is finished. The Venter will continue to run after the burner has finished firing for the set post-purge time cycle. The UC1 is set for a 2 minute post-purge time period from the factory. See "Pre / Post-Purge Settings" on page 3 for details.

The "1" input terminal on the UC1 can accept either a 24 VAC or 120 VAC control signal. IMPORTANT: The RED jumper must be positioned based on appliance interlock voltage. For most furnace applications it may be easier to interlock with the 24 VAC thermostat circuit. For most boiler applications it may be easiest to interlock with the 120 VAC aquastat or primary control circuit to the burner motor. Choose the interlock method that best fits your application. If using the "DRY" contact activation method, use terminals A & B on UC1 control and position the RED voltage jumper tab in the "DRY" position. See millivolt appliance interlock diagram for further information.

The steps listed under each diagram are intended as a supplement to the diagram. Wiring colors or designations may vary by manufacturer. If you are unable to wire the UC1 as outlined in these instructions, call Tjernlund's Customer Service Department toll free at 1-800-255-4208 for assistance.

IMPORTANT: To reset faults, verify fault by checking the LEDs and then remove call for heat.

UC1 UNIVERSAL CONTROL WIRING SCHEMATIC

The Ground lead, Venter motor and Fan Prover leads are factory connected to the UC1 circuit board. Venter Ground, motor and Fan Prover wiring connections are made at the free end of the 2 foot whip.

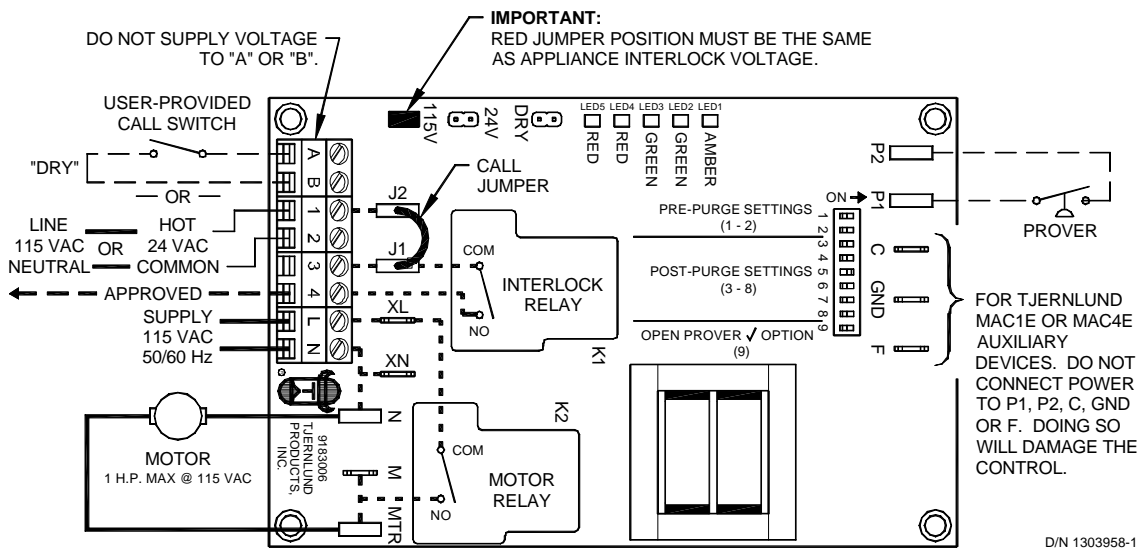
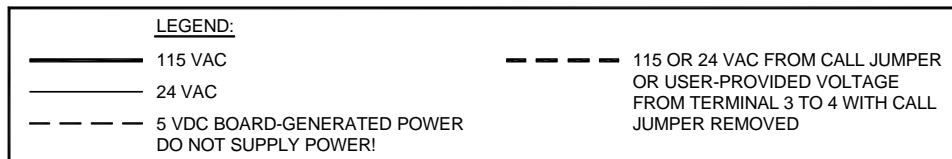

WARNING: Disconnect power supply from the UC1 and heating equipment when making wiring connections and servicing the Venter. Failure to do so may result in personal injury and/or equipment damage. LED #5 (RED) should be off with power removed.

VENTER GROUND, MOTOR AND PROVER SAFETY CIRCUIT CONNECTIONS

VENTER PROVER CONNECTIONS

Blue and Yellow leads from UC1 whip (P1 and P2) safety circuit must be connected to a Fan Prover switch. Leads are not polarity sensitive.

VENTER MOTOR CONNECTIONS

Connect Black and White motor leads from UC1 whip to Venter motor leads. Venter motor must not exceed 1 h.p. Make sure venter motor is wired for proper rotation. Consult motor nameplate for rotation.

VENTER GROUND CONNECTION

Connect Green ground lead from UC1 whip to Fan Prover ground screw along with ground from Venter motor.

MULTIPLE APPLIANCE INTERLOCKS

To interlock with one additional 24/115 VAC heater add the MAC1E. It is a stripped down auxiliary board version of the UC1 and is powered by and communicates with the UC1 through a factory wired whip.

To interlock more than two 24/115 VAC heaters, add the MAC4E for a total of up to 5 heaters. It is powered by and communicates with the UC1 through a factory wired whip.

To interlock a millivolt water heater and a 24/115 VAC furnace or boiler, add the WHKE and MAC1E.

MILLIVOLT INSTALLATIONS

Each millivolt appliance interlocked with the UC1 must have its own WHKE kit installed. The WHKE Gas Pressure Switch actuates the Venter through the A - B Dry contacts. The Linear Limit switch disables the heater in the event of a venting malfunction.

IMPORTANT: Each millivolt appliance interlocked with the UC1 must have its own Linear Limit spill switch.

UC1 UNIVERSAL CONTROL CONNECTED WITH A 24 VAC ELECTRONIC IGNITION MODULE

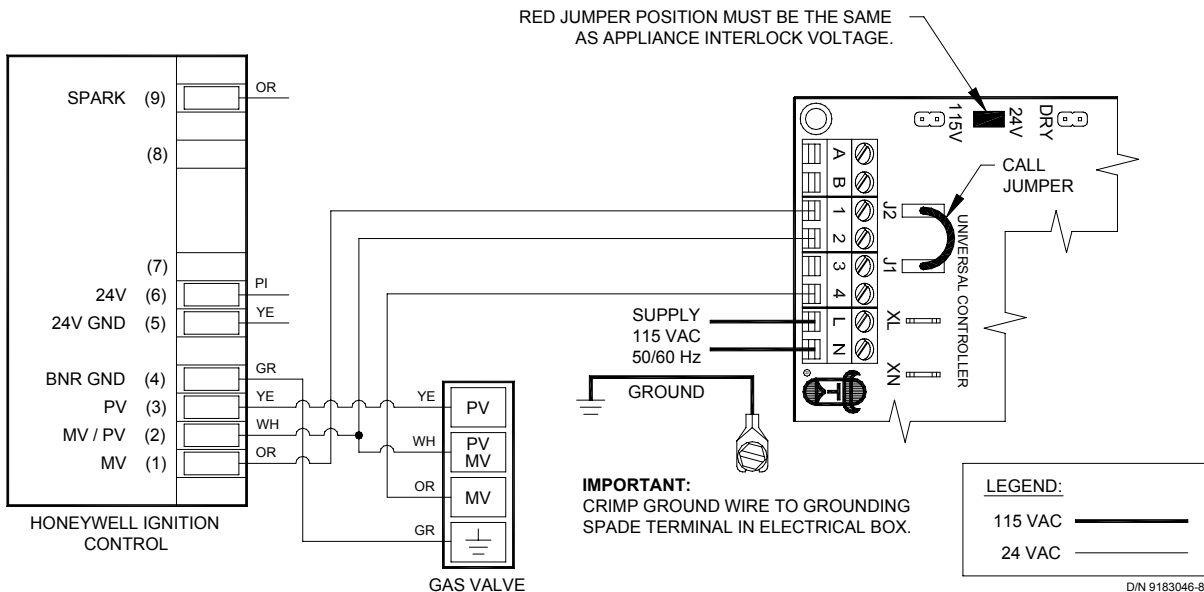

1. Remove the wire on MV at gas valve and connect it on #1 on UC1 terminal block.
2. Connect #2 on UC1 terminal block to MV/PV.
3. Connect #4 on UC1 terminal block to MV on gas valve.
4. Make sure RED voltage jumper on UC1 is on 24V.
5. Connect 115 VAC supply voltage to L & N terminals on UC1. Crimp Ground wire to grounding spade terminal in UC1.
Important: Installer must supply overload and disconnect protection.
6. If not previously completed, connect ground from UC1 whip to Venter ground. Connect Black and White leads from UC1 whip to Venter motor leads. Connect Blue and Yellow leads from UC1 whip to Fan Prover switch. Prover Leads are not polarity sensitive.

UC1 UNIVERSAL CONTROL CONNECTED WITH A SINGLE ZONE 24 VAC THERMOSTAT

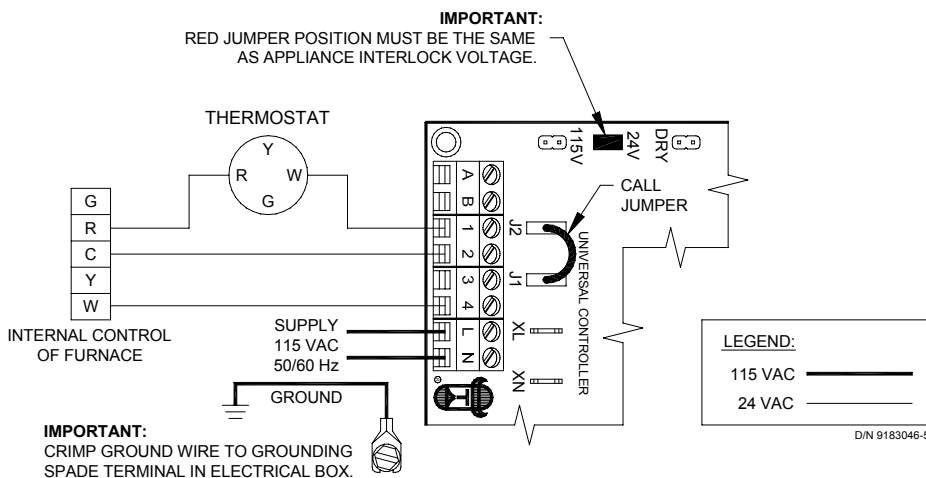

1. Connect W from t-stat to #1 on terminal block of UC1.
2. Connect #2 on UC1 terminal block to C on internal control terminal strip of furnace/boiler.
3. Connect #4 on UC1 terminal block to W on internal control terminal strip of furnace/boiler.
4. Make sure RED voltage jumper on UC1 is on 24V.
5. Connect 115 VAC supply voltage to L & N terminals on UC1. Crimp Ground wire to grounding spade terminal in UC1.
Important: Installer must supply overload and disconnect protection.
6. If not previously completed, connect ground from UC1 whip to Venter ground. Connect Black and White leads from UC1 whip to Venter motor leads. Connect Blue and Yellow leads from UC1 whip to Fan Prover switch. Prover Leads are not polarity sensitive.

UC1 UNIVERSAL CONTROL CONNECTED WITH A 24 OR 115 VAC STANDING PILOT

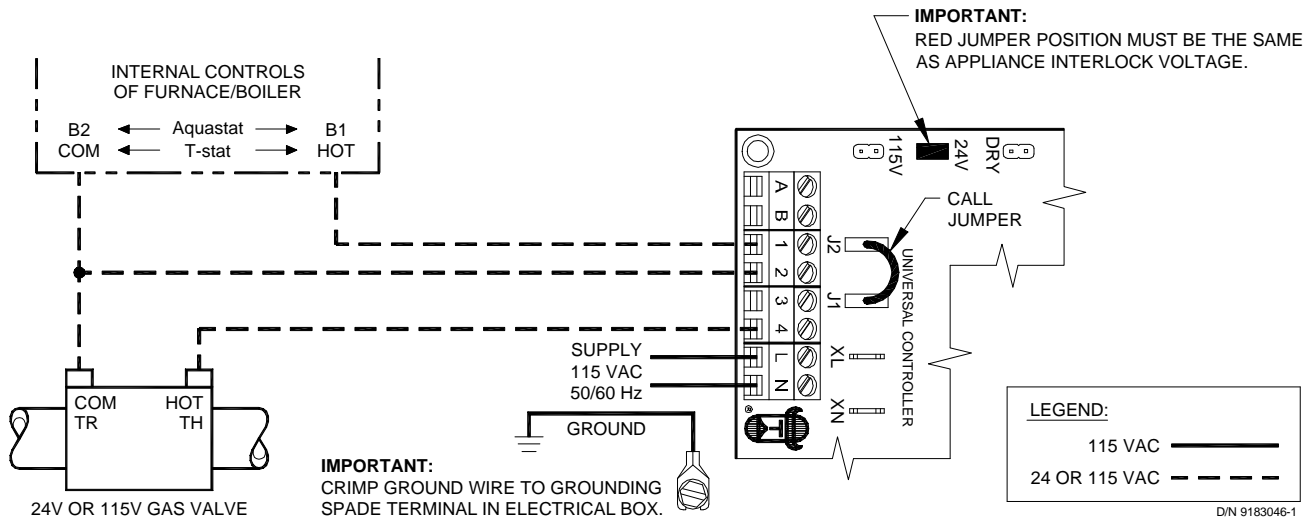

1. Remove the wire on TH or HOT of gas valve and connect it on #1 on UC1 terminal block.
2. Connect #2 on UC1 terminal block to TR or Common.
3. Connect #4 on UC1 terminal block to TH or HOT on gas valve.
4. Make sure RED voltage jumper on UC1 is on 24V or 115V depending on control voltage.
5. Connect 115 VAC supply voltage to L & N terminals on UC1. Crimp Ground wire to grounding spade terminal in UC1. Important: Installer must supply overload and disconnect protection.
6. If not previously completed, connect ground from UC1 whip to Venter ground. Connect Black and White leads from UC1 whip to Venter motor leads. Connect Blue and Yellow leads from UC1 whip to Fan Prover switch. Prover Leads are not polarity sensitive.

UC1 UNIVERSAL CONTROL AND WHKE INTERLOCK KIT CONNECTED WITH A MILLIVOLT APPLIANCE

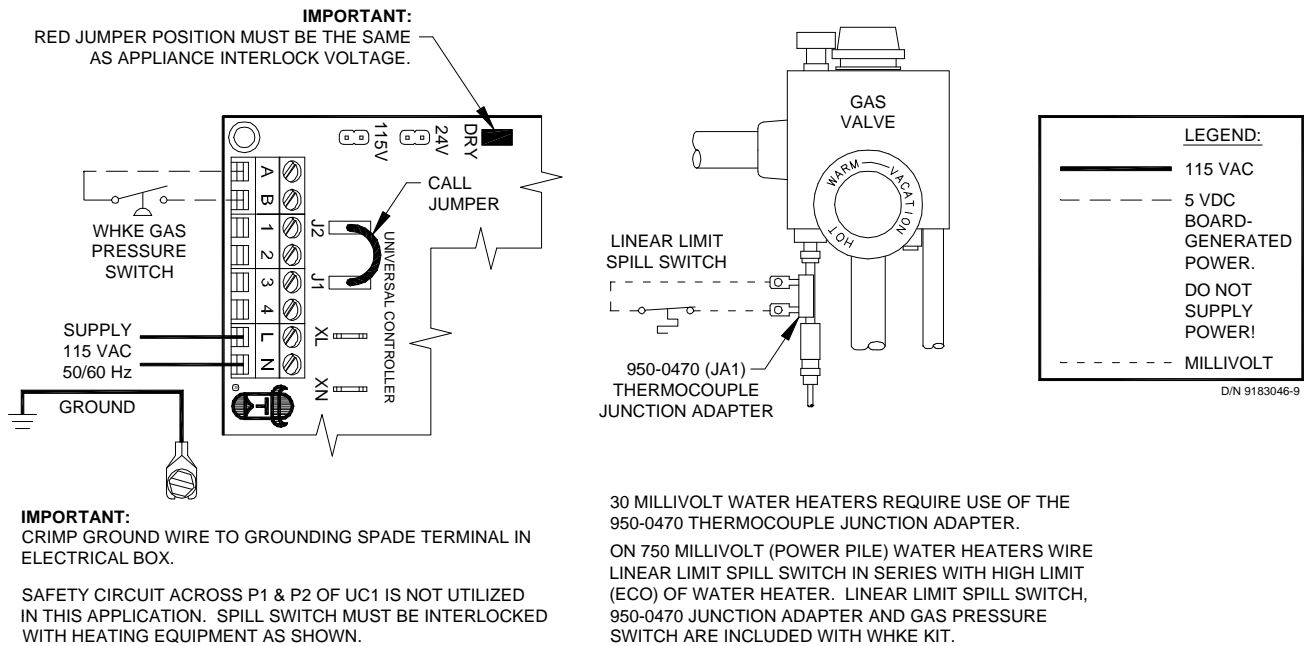

Each millivolt appliance interlocked with the UC1 must have its own WHKE kit installed. The WHKE Gas Pressure Switch actuates the Venter through the A - B Dry contacts. The Linear Limit switch disables the heater in the event of a venting malfunction.
IMPORTANT: Each millivolt appliance interlocked with the UC1 must have its own Linear Limit spill switch.

1. Wire WHKE Gas Pressure Switch in series with A and B terminal on UC1. Do not supply voltage to A and B terminals.
2. Wire WHKE Linear Limit in series with thermocouple junction adapter or high limit ECO of water heater.
3. Make sure RED voltage jumper on UC1 is in the DRY position.
4. Connect 115 VAC supply voltage to L & N terminals on UC1. Crimp Ground wire to grounding spade terminal in UC1. Important: Installer must supply overload and disconnect protection.
5. If not previously completed, connect ground from UC1 whip to Venter ground. Connect Black and White leads from UC1 whip to Venter motor leads. Connect Blue and Yellow leads from UC1 whip to Fan Prover switch. Prover Leads are not polarity sensitive. If using a Draft Inducer and only venting millivolt appliances the PS1505 Fan Proving Switch is not necessary, see WHKE instructions for complete details.

UC1 UNIVERSAL CONTROL CONNECTED TO A GAS OR OIL BURNER WITH AN AQUASTAT

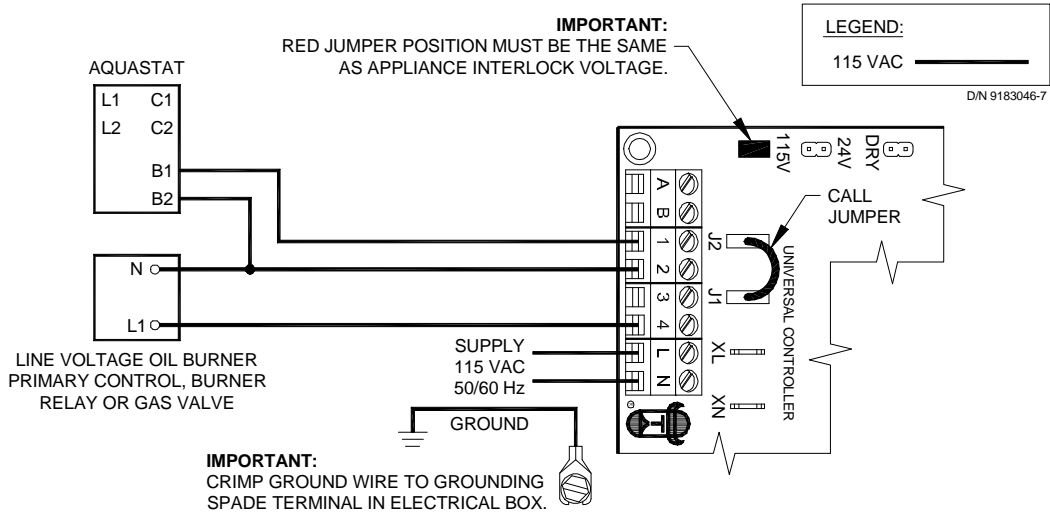

1. Disconnect B1 from L1 of oil burner primary control, burner relay or hot of gas valve and reconnect to #1 on UC1 terminal block.
2. Connect #2 on UC1 terminal block to B2 or N.
3. Connect #4 on UC1 terminal block to the L1 on line voltage oil burner primary control, burner relay or gas valve.
4. Make sure RED voltage jumper on UC1 is on 115V.
5. Connect 115 VAC supply voltage to L & N terminals on UC1. Crimp Ground wire to grounding spade terminal in UC1.
Important: Installer must supply overload and disconnect protection.
6. If not previously completed, connect ground from UC1 whip to Venter ground. Connect Black and White leads from UC1 whip to Venter motor leads. Connect Blue and Yellow leads from UC1 whip to Fan Prover switch. Prover Leads are not polarity sensitive.

NOTE: If burner primary control goes out on lockout, the Venter will continue to run as long as a call for heat is present.

UC1 UNIVERSAL CONTROL CONNECTED TO A HONEYWELL R7184 SERIES OR EQUIVALENT PRIMARY CONTROL WITH A LINE VOLTAGE THERMOSTAT OR AQUASTAT

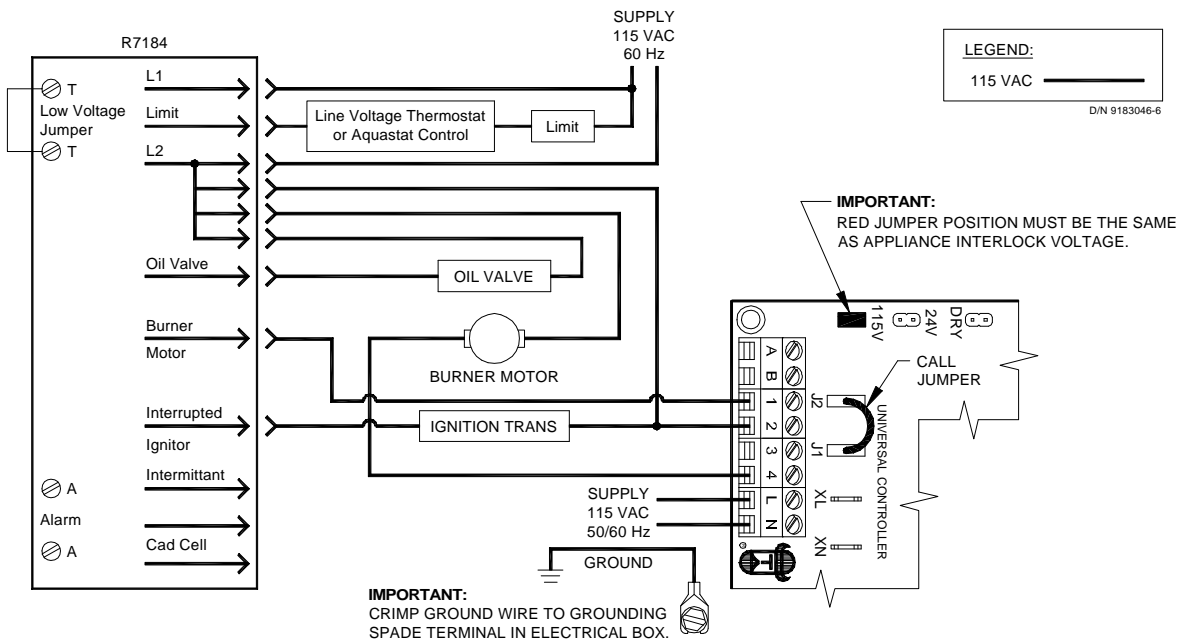

1. Disconnect burner motor wire off the R7184.
2. Connect burner motor terminal of R7184 to #1 on UC1 terminal block.
3. Connect #2 on UC1 terminal block to L2 or N.
4. Connect #4 on UC1 terminal block to burner motor wire removed from R7184.
5. Make sure RED voltage jumper on UC1 is on 115V.
6. Connect 115 VAC supply voltage to L & N terminals on UC1. Crimp Ground wire to grounding spade terminal in UC1.
Important: Installer must supply overload and disconnect protection.
7. If not previously completed, connect ground from UC1 whip to Venter ground. Connect Black and White leads from UC1 whip to Venter motor leads. Connect Blue and Yellow leads from UC1 whip to Fan Prover switch. Prover Leads are not polarity sensitive.

UC1 UNIVERSAL CONTROL CONNECTED WITH A CARLIN 40200, 42230, 48245, 50200, 60200 SERIES OR EQUIVALENT AND A LINE VOLTAGE THERMOSTAT OR AQUASTAT

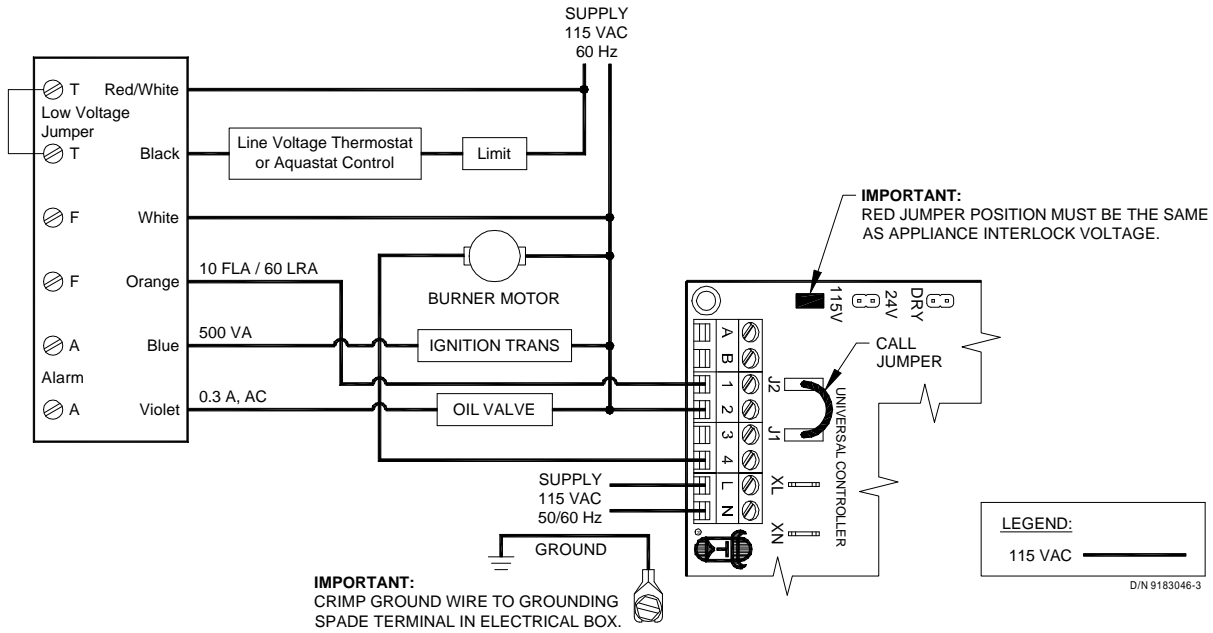

1. Disconnect burner motor wire off the Orange on Carlin.
2. Connect burner motor terminal Orange of Carlin to #1 on UC1 terminal block.
3. Connect #2 on UC1 terminal block to L2 or N
4. Connect #4 on UC1 terminal block to burner motor wire removed from Orange of Carlin.
5. Make sure RED voltage jumper on UC1 is on 115V.
6. Connect 115 VAC supply voltage to L & N terminals on UC1. Crimp Ground wire to grounding spade terminal in UC1. Important: Installer must supply overload and disconnect protection.
7. If not previously completed, connect ground from UC1 whip to Venter ground. Connect Black and White leads from UC1 whip to Venter motor leads. Connect Blue and Yellow leads from UC1 whip to Fan Prover switch. Prover Leads are not polarity sensitive.

UC1 UNIVERSAL CONTROL CONNECTED TO A HONEYWELL R8184 SERIES OR EQUIVALENT PRIMARY CONTROL

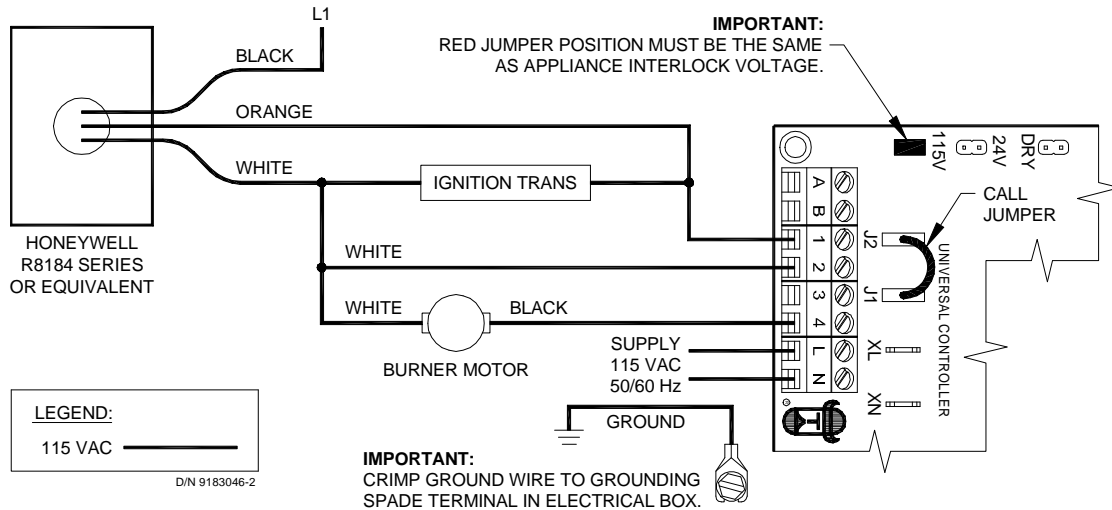

1. Separate the Black burner motor wire from the Orange wire of R8184 Primary Control.
NOTE: Do not separate the ignition transformer wire from the Orange.
2. Connect Orange wire of R8184 to #1 on UC1 terminal block.
3. Connect #2 on UC1 terminal block to White on R8184.
4. Connect Black of burner motor to #4 on UC1 terminal block.
5. Make sure RED voltage jumper on UC1 is on 115V.
6. Connect 115 VAC supply voltage to L & N terminals on UC1. Crimp Ground wire to grounding spade terminal in UC1. Important: Installer must supply overload and disconnect protection.
7. If not previously completed, connect ground from UC1 whip to Venter ground. Connect Black and White leads from UC1 whip to Venter motor leads. Connect Blue and Yellow leads from UC1 whip to Fan Prover switch. Prover Leads are not polarity sensitive.

UC1 UNIVERSAL CONTROL CONNECTED WITH A HONEYWELL R8184 SERIES OR EQUIVALENT PRIMARY CONTROL AND A BURNER MOTOR POST-PURGE

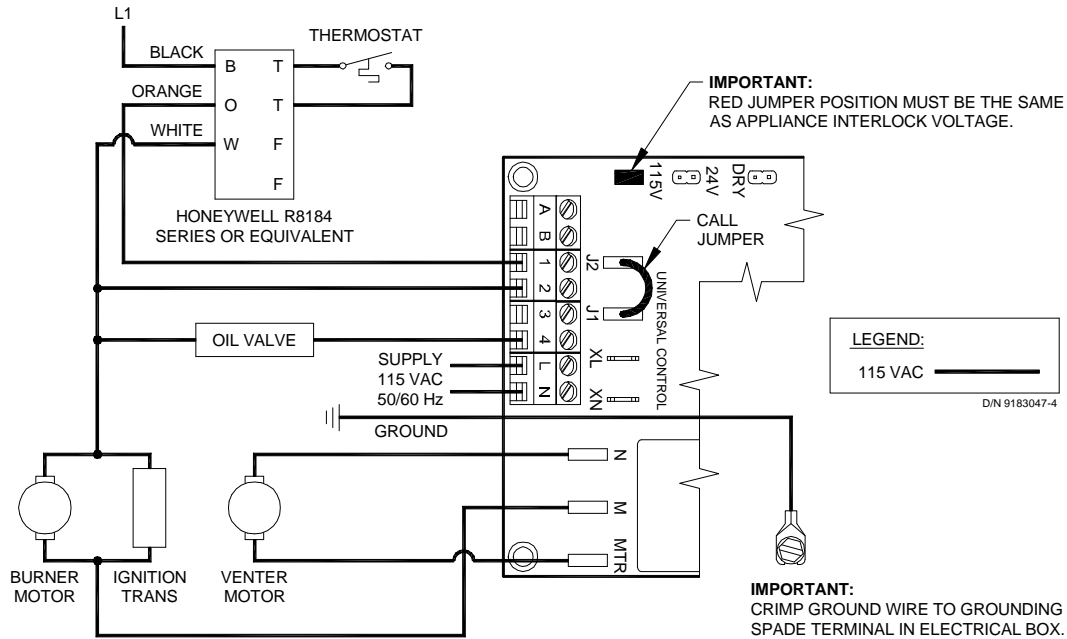

1. Separate the burner motor wire and ignition transformer from the Orange wire of R8184.
2. Connect the Orange of R8184 to #1 on UC1 terminal block.
3. Connect #2 on UC1 terminal block to White on R8184 or N.
4. Connect the HOT wire of oil solenoid valve to #4 on UC1 terminal block and neutral wire to White or N.
5. Connect burner motor and ignition transformer HOT wires to M terminal on UC1 and neutrals to White or N.
6. Make sure RED voltage jumper on UC1 is on 115V.
7. Connect 115 VAC supply voltage to L & N terminals on UC1. Crimp Ground wire to grounding spade terminal in UC1.
Important: Installer must supply overload and disconnect protection.
8. If not previously completed, connect ground from UC1 whip to Venter ground. Connect Black and White leads from UC1 whip to Venter motor leads. Connect Blue and Yellow leads from UC1 whip to Fan Prover switch. Prover Leads are not polarity sensitive.

UC1 UNIVERSAL CONTROL OPERATIONAL CHECK

1. Confirm power is supplied to the Control. LED #5 (RED) should be on.
2. Activate the UC1 by initiating an appliance call for heat. LED #1 (AMBER) should be on.
3. The motor relay will close and activate the Venter motor. LED #3 (GREEN) should be on.
4. If the safety circuit across P1 & P2 (Venter Prover) is closed, indicating an approved condition, the appliance interlock relay will close making terminal #3 closed to terminal #4. LED #2 (GREEN) should be on.
5. Remove power to the UC1 and any interlocked appliances. The LED #5 (RED) or any LED's should not be on. Test the safety circuit by removing the Blue or Yellow Lead from Fan Proving Switch. Do not let the opened LEAD touch a ground or damage may occur to the control when power is Reestablished. Reestablish power to the UC1 and interlocked appliances and initiate an appliance call for heat. After 60 seconds a Prover Start Up fault should arise with LED #4 (RED) and LED #5 (RED) flashing in unison.
6. Remove appliance call for heat and power to the UC1 and any interlocked appliances. The LED #5 (RED) or any LED's should not be on. Reconnect Blue or Yellow Fan Prover lead to Fan Proving Switch terminal removed from in step 5.
7. Reestablish power to UC1 and interlocked appliances and initiate a call for heat to confirm proper operation of UC1 and appliance.

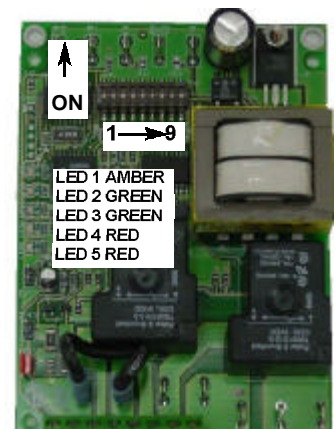

⚠ WARNING

The installer must perform Draft Check, Safety Interlock and Combustion Air Test as outlined in the Venter installation manual. If Venter installation manual is not present use the following procedure below.

The Fan Proving Switch is designed to disable the appliance gas valve or burner motor upon Venter failure only! It is not designed and cannot replace, regular vent system inspection, appliance servicing and combustion testing.

1. Close all doors and windows of the building. If the appliance is installed in a utility room or closet, close the entrance door to this room. Close fireplace dampers.
2. Turn on clothes dryer and all exhaust fans such as range hoods, bathroom exhausts and whole house fans to maximum speeds. Do not operate a fan used strictly for Summer exhausting.
3. Following the appliance manufacturer's instructions, place the appliance in operation, set thermostat for continuous operation.
4. Verify that Venter operates first, prior to burner ignition. Watch to make sure burner lights off properly.

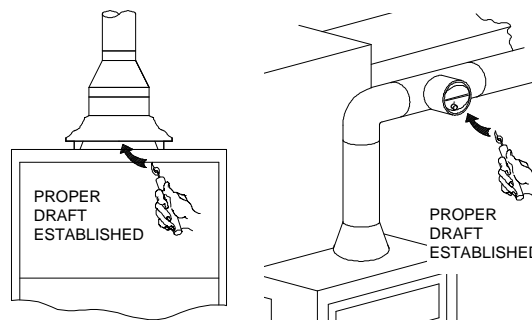

GAS

After allowing appliance(s) to operate for 15 minutes, follow the appliance manufacturers instructions to verify that the recommended draft is present. In general, most gas appliances will operate safely with flue outlet draft levels from -0.02 to -0.05" W.C.. If the draft is excessive, make necessary adjustments to the barometric control and/or follow the, "Venter Air Flow Damper Adjustment" procedure outlined in Venter installation manual. As a cross check, a candle or match can be held adjacent to the draft hood or barometric control to verify flame/smoke is being drawn into, and not rolling out of edge of the relief opening, (See Diagram above). If exhaust gases are escaping from the relief opening of the draft hood or barometric control, the equipment should not be operated until proper adjustments or repairs are made to provide adequate draft levels.

OIL

After allowing equipment to operate for 15 minutes, make necessary adjustments to the primary air intake and barometric draft control to comply with the manufacturer recommended over-fire draft and CO₂ requirements of the burner. In most cases, the over-fire draft should be in a range of -.02" to -.04" W.C. If adjustments to the primary air intake and barometric draft control do not provide the required over-fire draft, the Venter draft adjustment must be repositioned accordingly. Measure over-fire draft and CO₂ after repositioning Venter draft adjustment. Follow the "Venter Air Flow Damper Adjustment" procedure outlined in Venter installation manual.

5. Next, turn on all other fuel-burning appliances within the same room so they will operate at their full input. Repeat Step 3 above, checking the draft on each appliance.

TROUBLESHOOTING ELECTRICAL PROBLEMS

⚠ WARNING

The following guide is intended to be used if a problem occurs during the use of the Venter and UC1. It may be necessary to measure voltage during troubleshooting. **Extreme caution must be exercised to prevent injury.** If you are unable to determine the defective part with the use of this guide, call your Tjernlund distributor or Tjernlund Products direct at 1-800-255-4208 for further assistance.

IMPORTANT: To reset faults, verify fault by checking the LEDs and then remove call for heat.

LED STATUS & FAULT INDICATORS

LED INDICATOR LIGHTS

- LED #1 (Amber) Appliance call for heat.
- LED #2 (Green) Safety circuit through P1 & P2 (Venter Fan Prover) is verified "Open" upon start-up. Burner circuit is energized with contact closure from terminal 3 to 4. Also verifies Venter prover is closed during run cycle.
- LED #3 (Green) Power switched to Venter motor from L to MTR & M.
- LED #4 (Red) Status indicator.
- LED #5 (Red) 115 VAC power supplied to board. Also used as status indicator.

LED INDICATOR LIGHT STATUS & FAULTS

- LED #4 & #5 Flashing Alternately = Prover start up fault. Venter Prover contacts "Closed" across P1 & P2 upon appliance call before Venter is turned on. Prover status check **must** be activated, see page 3.
- LED #4 & #5 Flashing in Unison = Fan Prover circuit is "Open" longer than 60 seconds on start-up or 10 seconds during run cycle. Venter Prover contacts are not staying "Closed" across P1 & P2 safety circuit.
- LED #4 Flashing & #5 on Continuous = System in Pre-Purge. (Pre-Purge options 0, 15, 30, 60 seconds)
- LED #5 Flashing & #4 on Continuous = System in Post-Purge. (Post-Purge options 0, 30 seconds or 1, 2, 4, 8, 16 minutes)

SYMPTOM 1: VENTER OPERATES CONTINUOUSLY

Verify that Venter is not in post-purge mode which could last up to 16 minutes. A factory post-purge has been set for 2 minutes. LED #4 (Red) will be on continuously and LED #5 will be flashing during post-purge. A Venter pre-purge could also be set for up to 1 minute. LED #4 (Red) will be flashing and LED #5 will be on continuously during a Venter pre-purge. See "Pre / Post-Purge Settings" on page 3.

Verify that LED #1 (Amber) is not lit.

Yes, LED #1 (Amber) is lit: Check interlock wiring. UC1 control is receiving constant call for heat signal.

LED #1 (Amber) is not lit: Replace UC1 circuit board part number 950-8801.

SYMPTOM 2: VENTER MOTOR DOES NOT OPERATE

Verify that UC1 control has power, LED #5 (Red) should be lit. Verify that LED# 4 (Red) or LED# 5 (Red) are not flashing in Unison or Alternately. See "LED Status & Fault Indicators", above.

No: Check circuit breaker, disconnect switches and wiring. Confirm that motor leads are connected to N & MTR terminals.

Yes, LED #5 (Red) is lit: Verify that the interlocked burner is calling for heat, LED #1 (Amber) should be lit.

No, LED #1 (Amber) is not lit: Verify interlock wiring and that thermostat/aquastat is adjusted to call for heat. Verify that the RED voltage selection jumper is installed so that it matches the voltage of the interlocked burner.

Yes, LED #1 (Amber) is lit: Verify Prover safety circuit fault does not exist. See, "LED Status & Fault Indicators", above.

If faults exist check Prover P1 & P2 safety circuit.

If no faults exist, check for 115 VAC across terminals N and MTR.

Voltage present: Confirm Black and White leads from UC1 whip are securely fastened to motor leads in Venter. If so, replace Venter motor.

No voltage present: Replace UC1 circuit board part number 950-8801.

SYMPTOM 3: UC1 OPERATES, BUT BURNER DOES NOT

NOTE: Prover status check **must** be activated when side wall venting, see page 3. For any newly established call for heat the UC1 will run for 60 seconds to try to close the fan prover circuit (P1 to P2). If circuit can not be made after 60 seconds LED's 4 & 5 (Red) will flash in unison, indicating a prover check circuit fault on UC1 start up. The UC1 will shut down and LED's 4 & 5 (Red) will flash in unison, indicating a prover check circuit fault on UC1 start up. NOTE: If primary control of oil burner locks out during the 1 minute period the UC1 safety circuit and LED's 4 & 5 will be reset. If the fan prover makes on start up, but breaks for more than 10 seconds during the burner cycle, LED's 4 & 5 (Red) will flash in unison indicating a prover circuit fault. The UC1 will continue to run for 10 minutes to try to make the prover circuit as long as a call for heat exists. After 10 minutes the UC1 will shut down and LED's 4 & 5 (Red) will flash in unison indicating a prover circuit fault. Remove the call for heat and then reestablish to reset the UC1 prover safety circuit (P1 to P2) & LED's.

Verify that LED #2 (Green) is lit.

Yes, LED #2 (Green) is lit: Verify that "call jumper" is connected from J1 to J2 on UC1 circuit board. With call for heat established, verify that wiring is correct by measuring voltage between terminals 1 & 2 and 2 & 4 of UC1 terminal strip. Voltage should be the same in both cases, if not rewire per appropriate diagram. NOTE: If using the "Dry Contact" interlock method, make sure that the RED voltage selection jumper is installed on the dry contact tabs.

No, LED #2 (Green) is not lit: Remove call for heat and reestablish a call for heat to reset control. Within 1 minute of call for heat, carefully jump a wire between P1 & P2 on UC1 control. LED #2 (Green) should light.

No, LED #2 (Green) does not light: Replace UC1 circuit board, part number 950-8801.

Yes, LED #2 (Green) lights up: Remove supply power to UC1. Remove Jumper from P1 & P2. The fan proving switch is not closing or wiring connections are incorrect/broken. Disrupt call for heat. Remove leads from Fan Prover and initiate a call for heat. With Venter running, verify that Venter performance is sufficient to close Fan Prover contacts by checking for continuity across switch.

No, continuity is not present: Visually inspect system for blockages. Confirm that maximum Venter BTU/hr. input and vent pipe lengths are not exceeded or elbows are not installed directly on Venter discharge. If okay, replace fan prover.

Yes, continuity present: Recheck wiring.

HOW TO OBTAIN SERVICE ASSISTANCE

1. If you have any questions about your Universal Control or if it requires adjustment or repair, we suggest that you contact your installer, contractor or service agency.
2. If you require technical information contact Tjernlund Products, Inc. at 1-800-255-4208.

When contacting Tjernlund Products, Inc., please have the following information available:

1. Model of the Venter that UC1 is interlocked with as shown on the label attached to Venter.
2. Name and address of installer and any service agency who performed work on Venter.
3. Date of original installation and dates any service work was performed.
4. Details of the problem as you can best describe them.

LIMITED PARTS WARRANTY AND CLAIM PROCEDURE

Tjernlund Products, Inc. warrants the components of the UC1 for one year from date of installation. This warranty covers defects in material and workmanship. This warranty does not cover normal maintenance, transportation or installation charges for replacement parts or any other service calls or repairs. This warranty DOES NOT cover the complete UC1 if it is operative, except for the defective part.

Tjernlund Products, Inc. will issue credit or provide a free part to replace one that becomes defective during the one year warranty period. Proof of date of the installation in the form of the contractor sales/installation receipt is necessary to prove the unit has been in service for under one year. All receipts should include the date code of the UC1 to ensure that the defective component corresponds with the complete unit. This will help preclude possible credit refusal.

- 1.) Follow troubleshooting guide to determine defective component. If unable to determine faulty component, contact your Tjernlund distributor or Tjernlund Products Technical Customer Service Department at 1-800-255-4208 for troubleshooting assistance.
- 2.) After the faulty component is determined, return it to your Tjernlund distributor for replacement. Please include UC1 date code component was taken from. The date code is located on the Electrical Box coverplate. If the date code is older than 1 year, you will need to provide a copy of the original installation receipt to your distributor. Credit or replacement will only be issued to a Tjernlund distributor after the defective part has been returned prepaid to Tjernlund.

WHAT IS NOT COVERED

- Product installed contrary to our installation instructions
- Product that has been altered, neglected or misused
- Product that has been wired incorrectly
- Product that has been damaged by a malfunctioning or mistuned burner
- Any freight charges related to the return of the defective part
- Any labor charges related to evaluating and replacing the defective part

TJERNLUND LIMITED ONE YEAR WARRANTY

Tjernlund Products, Inc. warrants to the original purchaser of this product that the product will be free from defects due to faulty material or workmanship for a period of (1) year from the date of original purchase or delivery to the original purchaser, whichever is earlier. Remedies under this warranty are limited to repairing or replacing, at our option, any product which shall, within the above stated warranty period, be returned to Tjernlund Products, Inc. at the address listed below, postage prepaid. THERE ARE NO WARRANTIES WHICH EXTEND BEYOND THE DESCRIPTION ON THE FACE HEREOF, AND TJERNLUND PRODUCTS, INC. EXPRESSLY DISCLAIMS LIABILITY FOR INCIDENTAL OR CONSEQUENTIAL DAMAGES ARISING FROM THE USE OF THIS PRODUCT. THIS WARRANTY IS IN LIEU OF ALL OTHER EXPRESS WARRANTIES AND NO AGENT IS AUTHORIZED TO ASSUME FOR US ANY LIABILITY ADDITIONAL TO THOSE SET FORTH IN THIS LIMITED WARRANTY. IMPLIED WARRANTIES ARE LIMITED TO THE STATED DURATION OF THIS LIMITED WARRANTY. Some states do not allow limitation on how long an implied warranty lasts, so that limitation may not apply to you. In addition, some states do not allow the exclusion or limitation of incidental or consequential damages, so that above limitation or exclusion may not apply to you. This warranty gives you specific legal rights and you may also have other rights which may vary from State to State. Send all inquiries regarding warranty work to Tjernlund Products, Inc. 1601 9th Street, White Bear Lake, MN 55110-6794. Phone (651) 426-2993 • (800) 255-4208 • Fax (651) 426-9547 • Email fanmail@tjfans.com.

REPLACEMENT PARTS

<u>Component</u>	<u>Part Number</u>
Universal Control Circuit Board	950-8801