

**OWNERS INSTRUCTIONS
THESE INSTRUCTIONS
MUST REMAIN
WITH EQUIPMENT
DO NOT DESTROY**

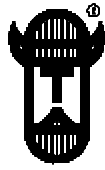

TJERNLUND PRODUCTS, INC.

1601 Ninth Street • White Bear Lake, MN 55110-6794
PHONE (651) 426-2993 • (800) 255-4208 • FAX (651) 426-9547
Visit our web site • www.tjernlund.com

PAI SERIES INTAKE HOODS

NOTE:

The PAI-Series Intake Hoods are only rated for the CFM capacities listed below. Use of these hoods for CFM capacities greater than listed will result in entrainment of rain or snow through the hood.

MAXIMUM CFM CAPACITIES

PAI-Model	Part#	Max. CFM Intake
PAI-3 Hood	950-0021	150 CFM
PAI-4 Hood	950-0022	250 CFM
PAI-5/6 Hood	950-0023	725 CFM
PAI-7 Hood	950-0024	1200 CFM

INTAKE HOOD DIMENSIONS

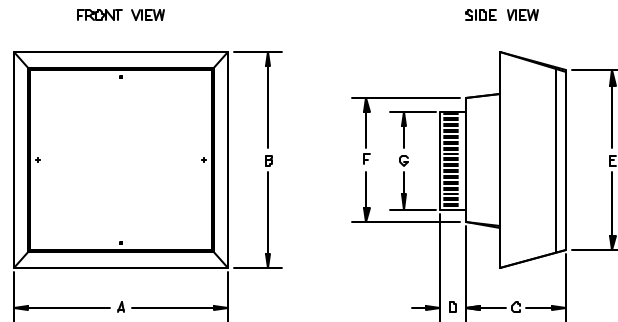

	A	B	C	D	E	F	G
PAI-3	14"	14"	6 1/4"	2 1/4"	12"	B"	B" DIA
PAI-4	17 1/2"	17 1/2"	8 1/2"	2 1/4"	14 1/2"	10"	8" DIA
PAI-5 & 6	23 1/2"	23 1/2"	8 1/4"	2 1/4"	20 1/4"	16 5/8"	10" DIA
PAI-7	29 1/2"	29 1/2"	8 3/8"	2 1/4"	26 1/8"	22 3/8"	12" DIA

INTAKE HOOD LOCATIONS - WALL MOUNT OR ROOF MOUNT

M-306.1 LOCATION:

Outside air exhaust and intake openings shall be located a minimum of 10 feet (3048mm) from lot lines or buildings on the same lot. When openings front on a street or public way, the distance shall be measured to the center-line of the street or public way.

M-306.1.1 INTAKE OPENINGS:

Outside air intake openings shall be located a minimum of 10 feet (3048mm) from any hazard or noxious contaminant such as vents, chimneys, plumbing vents, streets, alleys, parking lots and loading docks. When a source contaminant is located within 10 feet (3048mm) of an intake opening, such opening shall be located a minimum of 2 feet (610mm) below the contaminant source.

IN ADDITION TO THESE CODES THE MANUFACTURER RECOMMENDS THAT:

The Intake Hood should be a minimum of 1 foot above grade or anticipated snow line.

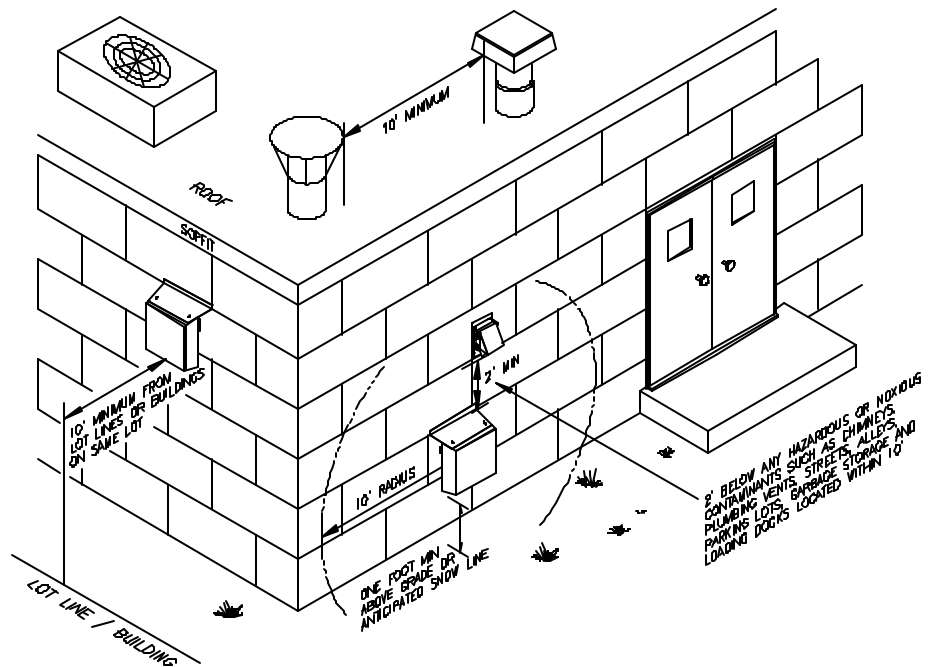

On wall installations, if possible, terminate the Intake Hood on a wall that does not face the direction of prevailing winds. This will diminish the possibility of wind infiltration.

INSTALLATION (TOOLS REQUIRED)

- Reciprocating saw
- 1/4", 5/16", 3/8" nut runner or socket
- Masonry chisel
- Drill and 1/4" bit
- Blade screwdriver

INSTALLATION OF INTAKE HOOD

Note: Before cutting opening through wall or roof, figure layout of pipe runs. Confirm Intake Hood location meets requirements above.

The Intake Hood is designed so relatively large amounts of outdoor air can be pulled in through a small wall or roof opening. If properly installed, rain and snow will not be pulled in with the outdoor air. Systems installed without the PAI-Series Intake Hood may be susceptible to the entry of rain or snow and CFM values can not be guaranteed.

The Intake Hood may be primed and painted to blend in with exterior.

ROOF MOUNT INSTALLATION OF INTAKE HOOD

1. Attach take-off collar to the Intake Hood Base by bending over the tabs of the collar. Screw galvanized pipe to take-off collar on Intake Hood base.
2. Verify that roof penetration will not come in contact with concealed wiring or plumbing. Cut a circular hole through the roof. (PAI-3 Rough-In: 6 1/2", PAI-4 Rough-In: 8 1/2", PAI-5/6 Rough-In: 10 1/2", PAI-7 Rough-In: 12 1/2")
3. Install 4 pieces of plumber's strap from the Intake Hood Base to the pipe. Use the provided 1/4" bolts, washers, and nuts to attach the straps to the hood. Use 2 sheet metal screws per strap to attach the straps to the pipe, (See Diagram A).
4. Secure Intake Hood cover to base with #8 x 3/8" sheet metal screws, PAI-3/4 (4), PAI-5/6 (8), PAI-7 (20), (See Diagram A).
5. Install roof flashing and storm collar. Clamp storm collar around galvanized pipe penetrating through to the interior. Intake Hood should be at least 2 feet above the roof.
6. Install Intake Hood backing plate on ceiling if desired with #10 x 1 1/4" screws provided, PAI-3/4 (4), PAI-5/6/7 (8).

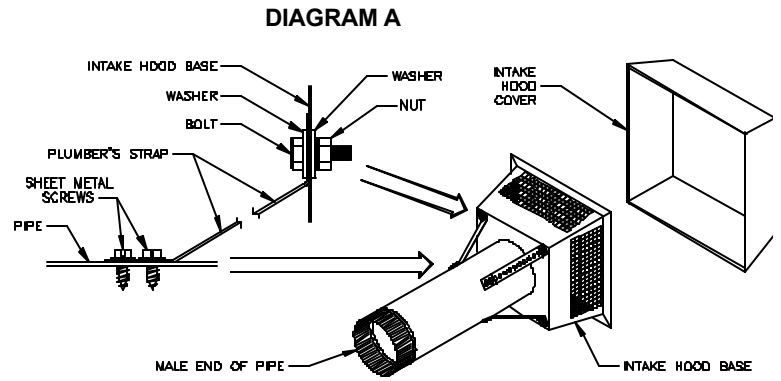

WALL MOUNT INSTALLATION OF INTAKE HOOD

1. Attach take-off collar to Intake Hood base by bending over the tabs of the collar.
2. Verify that wall penetration will not come in contact with concealed wiring or plumbing. Cut a circular or square opening through the wall. (PAI-3 Rough-In: 6 1/2", PAI-4 Rough-In: 8 1/2", PAI-5/6 Rough-In: 10 1/2", PAI-7 Rough-In: 12 1/2")
3. Secure section of galvanized pipe to Intake Hood collar with sheet metal screws.
4. Insert Intake Hood with pipe attached through opening and mark location of mounting holes, PAI-3/4 (4), PAI-5/6/7 (8), (See Diag. B). Drill 1/4" diameter holes at marked locations, insert plastic wall anchors (for masonry wall).
5. Apply a bead of caulk around perimeter of Intake Hood Base, (See Diagram C). Insert Intake Hood through opening, align mounting holes and secure to wall with #10 x 1 1/4" screws provided, PAI-3/4 (4), PAI-5/6/7 (8).
6. Secure Intake Hood Cover using #8 x 3/8" sheet metal screws, PAI-3/4 (4), PAI-5/6 (8), PAI-7 (20), (See Diagram D).
7. Apply a bead of caulk to the rear flange of the Rain Shield and position Rain Shield on the Intake Hood making sure it is adjusted flush against the wall. Use adjustment slot and pierce through hood dimples with (2) #8 x 3/8" sheet metal screws, (See Diagram E).

MODEL PAI-7 (950-0024) ONLY

When installing PAI-7 Hood apply Rain Shield with caulking over middle adjustment slot of rain shield. Install leak proofing tab between Rain Shield and Intake Hood, (See Diagram D).

8. Install Intake Hood backing plate on interior wall with provided #10 x 1 1/4" screws and wall anchors, PAI-3/4 (4), PAI-5/6/7 (8).

DIAGRAM B

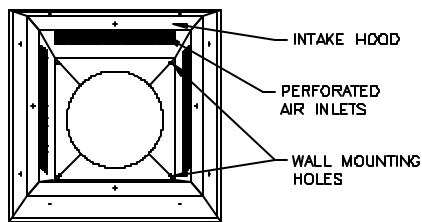

DIAGRAM D

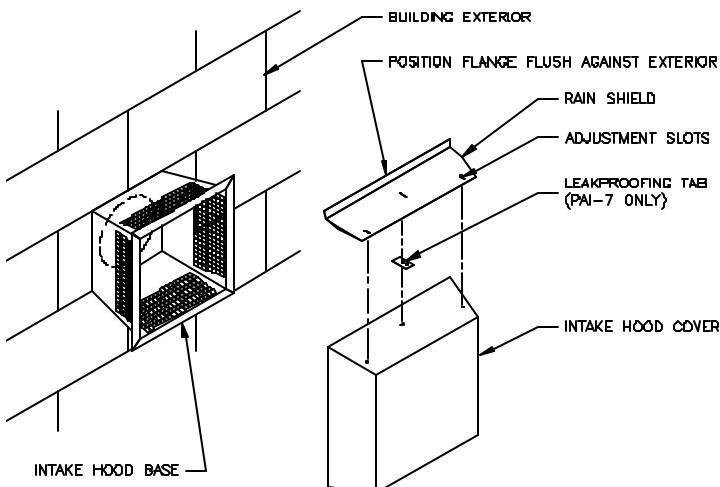

DIAGRAM C

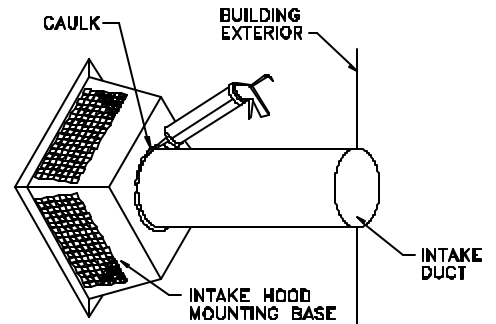

DIAGRAM E

